

INSTALL GUIDE

Nexkey NK201 One-Door Controller

V 2.1.1– May 2026





IMPORTANT WIRING WARNINGS



The following warnings must be read and followed.

Failure to follow these instructions will cause the Controller to either operate improperly or not at all and will void the warranty. These warnings apply to all wiring scenarios described in this manual.

Wiring Requirements and Limitations

- The Controller is not compatible with mag locks.
- Locking hardware requiring more than 3 amps is not supported.
- A jumper wire (green wire in diagram) must be installed from Power (Terminal 1) to COM #1 (Terminal 4).
- Disconnect all power from the Controller and locking hardware before wiring locks or any other peripherals.
- Only wire the controller as outlined in this manual. Any wiring methods not described are not supported.

TABLE OF CONTENTS



Introduction	Page
Pre-Installation Checklist	4-5
Technical Specs	6
What's in the box	7
Overview and LED Behavior	8

Installation	Page
Placement	9
Mounting	10
Wiring - Fail Secure Locking Hardware	11
Wiring - Fail Safe Locking Hardware	12
Connect to Wi-Fi	13
Testing the Controller	14
Wi-Fi Signal Strength (RSSI) Guidelines	15
Settings	16-17
Support & Version History	18



Commissioning a Controller

- Visit <https://store.nexkey.com/> and complete the controller commissioning process.
- After commissioning is complete, you will be granted access and receive a digital key to operate and test the controller.

Network & Connectivity

- The wireless network must broadcast in the 2.4GHz band. (5 GHz is not supported).
- Router or Wi-Fi access point should be within 30 feet of the Controller with minimal obstructions.
- The wireless network SSID must be broadcasting (not hidden). The Controller does not support the use of hidden networks nor captive portals.
- Factor the materials used in the building construction when determining access point placement, such as metal or steel doors, thickness and materials used in walls and line of sight.
- Do not install the router or access point inside a metal enclosure, as this will significantly reduce signal strength.
- For local unlocks, the user's mobile device must have an active cellular data or Wi-Fi connection.



Power Requirements

- Determine total power consumption before installation.
 - Add the amperage of the Controller + locking hardware + any peripherals.
- If total power consumption exceeds 1 amp, a third-party power supply is required.
- The provided power supply is 24 VDC @ 1 amp.
- Only use the provided power supply when connecting to 24 VDC locking hardware.
- If battery backup is required, a compatible third-party power supply with battery backup must be purchased separately from your preferred supplier.
- Locking hardware requiring more than 3 amps is not supported.

Wiring Requirements

- Use 18 AWG wire with a maximum run length of 500 feet.
- All wiring must comply with:
 - National Electrical Code (NEC), ANSI/NFPA 70
 - Local electrical codes
 - Requirements of the authority having jurisdiction (AHJ)

Door & Hardware Readiness

- Confirm the door is equipped with a properly functioning door closer.
- Ensure the opening is in good working condition:
 - No door dragging
 - Proper alignment
 - Smooth operation

TECHNICAL SPECIFICATIONS



Specification	Description
Power Consumption	Idle, Wi-Fi off: < 50 mA Idle, Wi-Fi on: 50–150 mA Short peak during activity: < 300 mA
Power Input	24VDC or 12VDC
Reader	Integrated reader. No external reader required.
Relay Outputs	(2) dry relay for auxiliary output with maximum pass-through current of 12/24VDC @ 3A (resistive load)
Hardware Version	1.2
Dimensions	4.25 x 3.75 x 1.3 in
Wi-Fi requirements	2.4ghz only
Unlock Credential	Nexkey Mobile App & Apple Watch
Device Requirements	iOS 16.6 or later, Android 11 and up

WHAT'S IN THE BOX



Controller

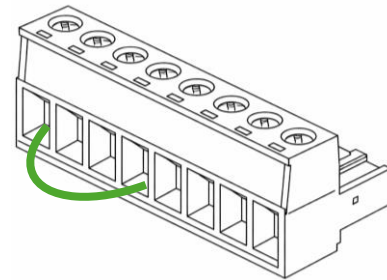

8 Position Terminal Block Plug w/ jumper wire



24VDC @ 1A
Power Supply

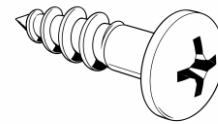

(2) Mounting screws

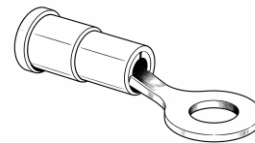

(3) Ring terminals

What you'll need

- A working internet connection
- A smartphone or tablet
- A #2 Phillips screwdriver or drill with a #2 Phillips bit
- 1/8" Flathead screwdriver

OVERVIEW AND LED BEHAVIOR



1. Power
2. GND
3. NC #1
4. COM #1
5. NO #1
6. NC #2
7. COM #2
8. NO #2

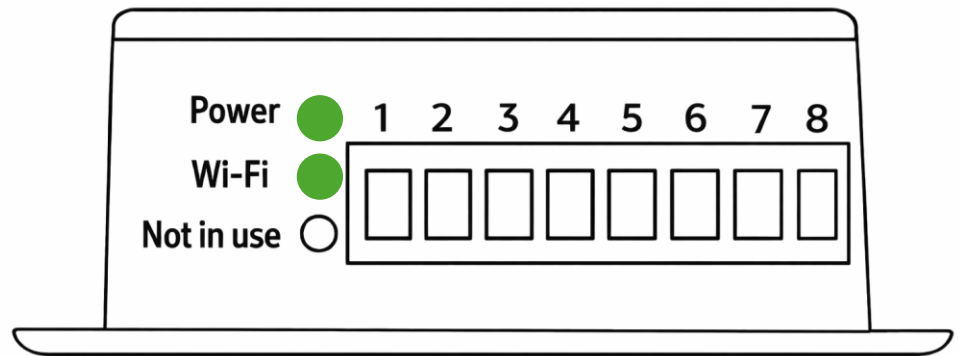

Controller LED Status Indicators

The Controller does not have labeled LEDs as shown in the image above. For reference in this manual, they are defined as follows:

1. Power
2. Wi-Fi
3. Not in use

All controller LEDs illuminate green only.

LED Behavior

Power (LED 1)

- Blinking: Controller has power
- Solid: Door is unlocked due to a nearby unlock event

Wi-Fi Connection (LEDs 1 & 2)

- LED 1 and LED 2 blinking: Controller is connected to Wi-Fi
- LED 1 and LED 2 solid: Door is currently unlocked due to one of the following:
 - Nearby unlock
 - Business hours schedule
 - “Unlock Until” command
 - Remote unlock
 - Any active unlock schedule

PLACEMENT



Unlike traditional access controllers that are mounted in a closet or other remote location, the Nexkey controller must be installed within 20 feet of the door.

This is because the Nexkey controller communicates directly with nearby mobile devices at the door, rather than using a separate wall-mounted reader.

Surface Mount Wiring

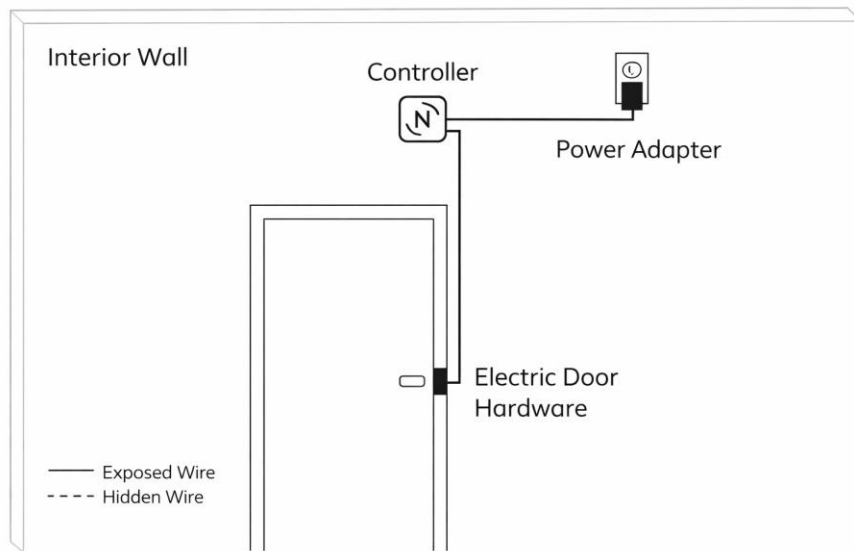

Concealed Mount Wiring

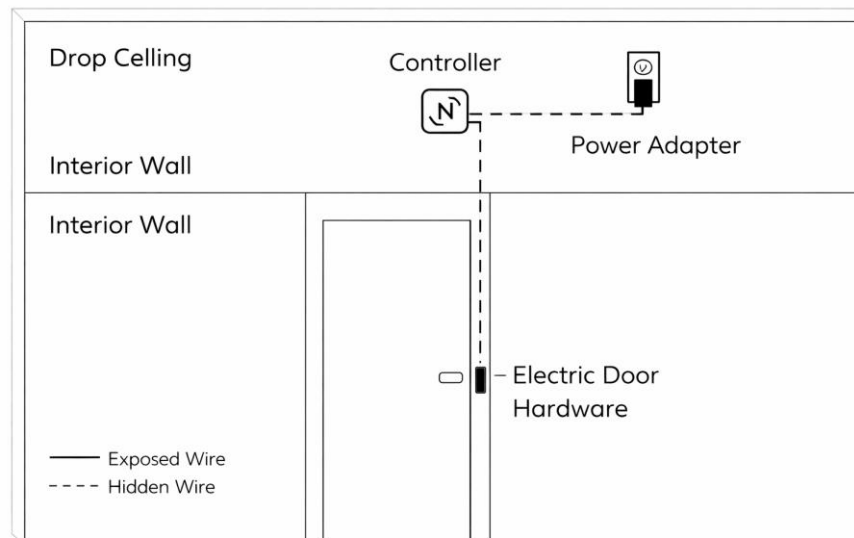

MOUNTING



The Controller may be mounted using (2) provided screws. Other options are double sided Velcro or 3M adhesive that can be purchased separately.

Mounting Guidelines

- Install the Controller above the door frame, on the interior side of the door.
- Mount within 20 feet of the door.
- Position the Controller as high and as close to the door as possible for optimal signal strength.
- Be aware that building materials may affect signal strength.

Optional Placement

- The Controller may be hidden above a drop ceiling or placed out of visual line of sight, provided distance and signal requirements are met.

Enclosure Considerations

- If installing the Controller inside a watertight enclosure, avoid metal enclosures.
- Metal enclosures will degrade Wi-Fi and overall signal strength.

Power Configuration

- Wiring shown is for Fail Secure locking hardware using the provided 24 VDC @ 1A power supply.
- Use the Normally Open (NO) relay output on the Controller.

Power Capacity Requirements

- If the total power consumption of the Controller, locking hardware, and any peripherals exceeds 1 amp, a third-party power supply is required.

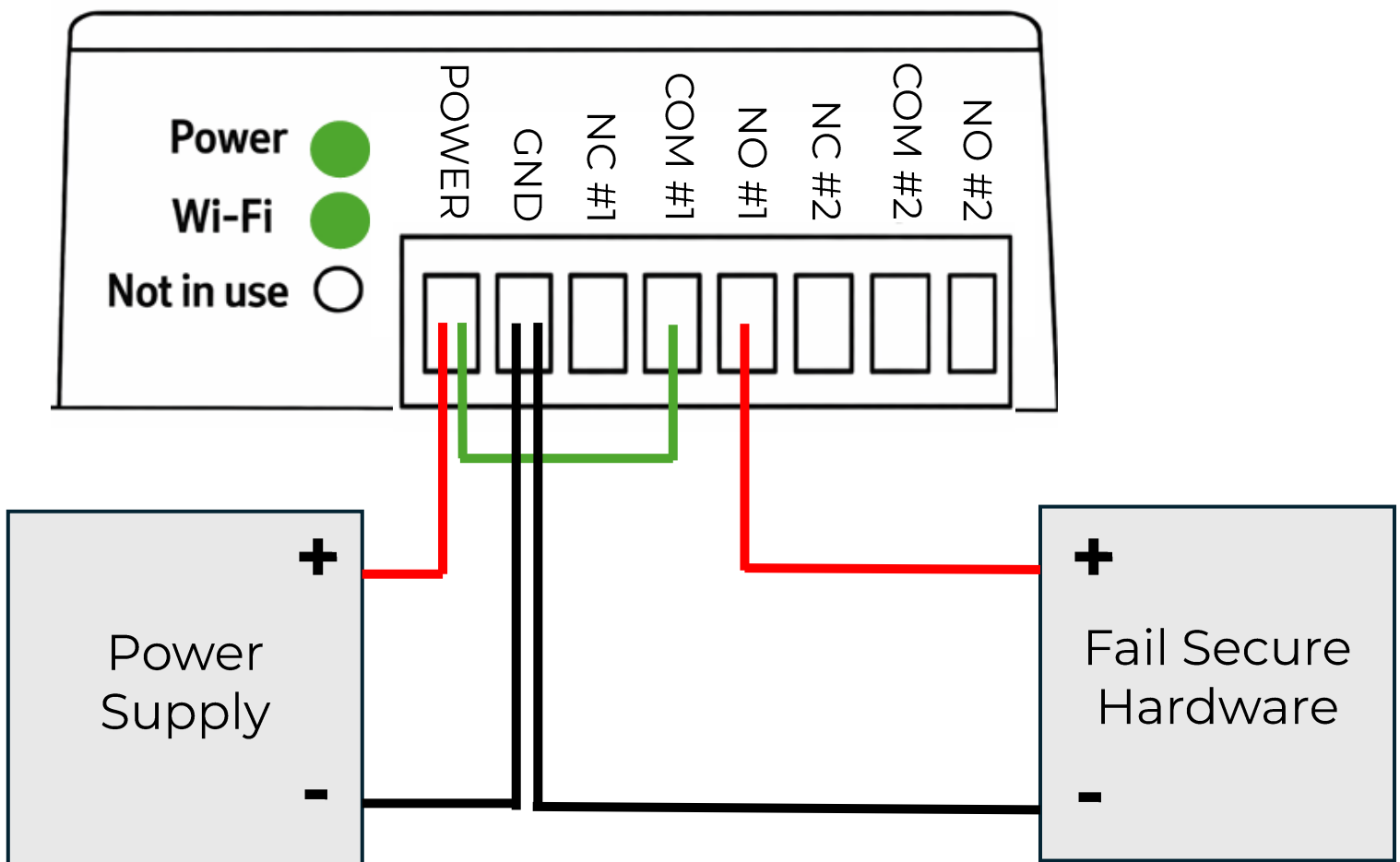

WIRING – FAIL SAFE LOCKING HARDWARE



Power Configuration

- Wiring shown is for Fail Safe locking hardware using the provided 24 VDC @ 1A power supply.
- Use the Normally Closed (NC) relay output on the Controller.

Power Capacity Requirements

- If the total power consumption of the Controller, locking hardware, and any peripherals exceeds 1 amp, a third-party power supply is required.

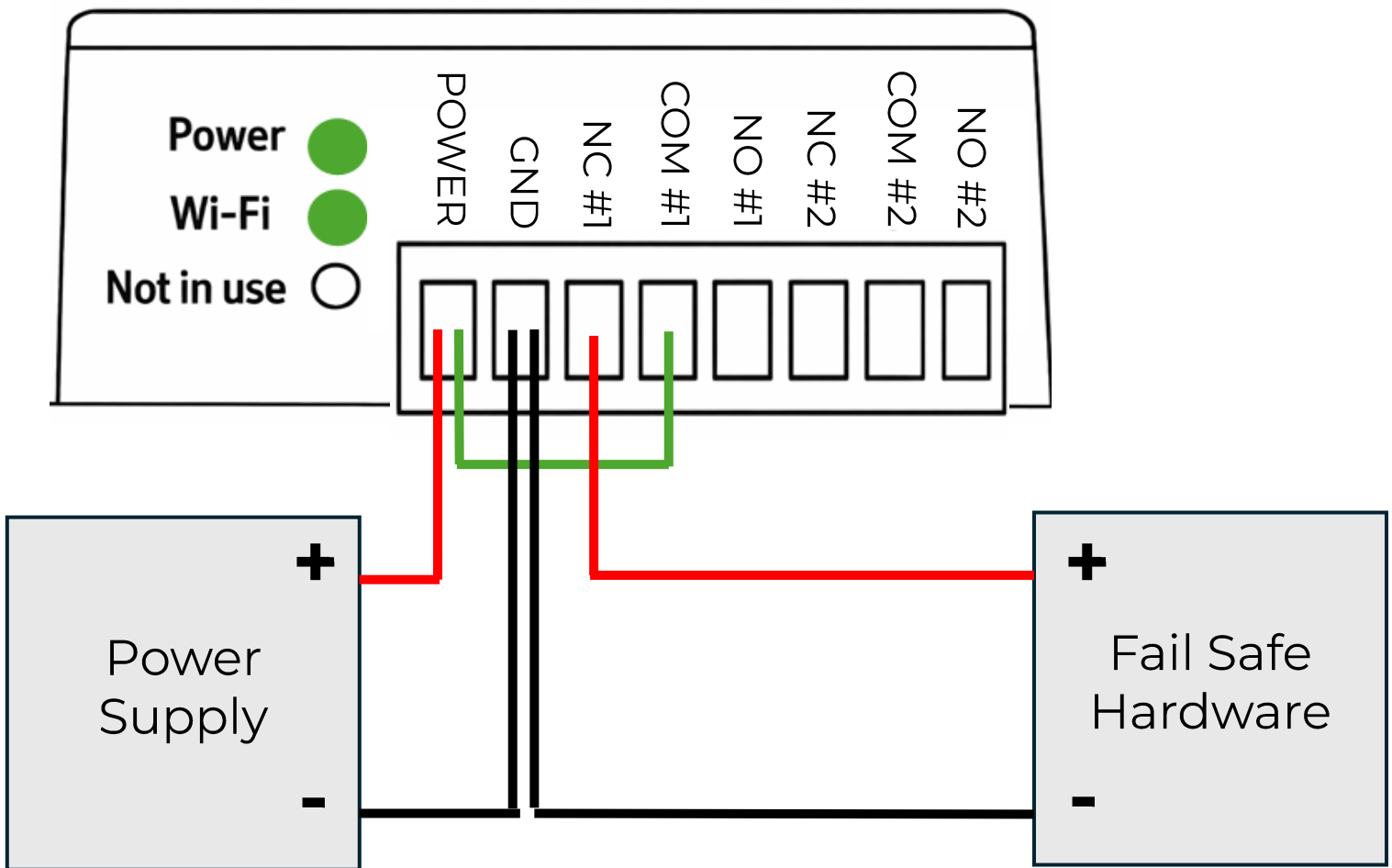

CONNECT TO WI-FI



Connecting the Controller to Wi-Fi enables Remote Unlocking, Text Keys, and Business Hours functionality.

If these features are not required, connecting to Wi-Fi is optional.

Connecting the Controller to Wi-Fi is performed through a mobile device. You will need to be within 10 feet of the Controller.

Wi-Fi Configuration

1. Select the Key in the app.
2. Navigate to Settings, then scroll to Wi-Fi Configuration.
3. A list of networks will appear on the next screen.
4. Select the network, enter the Wi-Fi password and tap Save.
5. Allow the Controller to complete configuration.
 1. When Wi-Fi is successfully connected, LED 1 (Power) and LED 2 (Wi-Fi) will blink, indicating an active Wi-Fi connection.
 2. The app will display configured, restarted.
6. If configuration fails, power cycle the Controller (unplug for 15 seconds) and repeat the steps above.

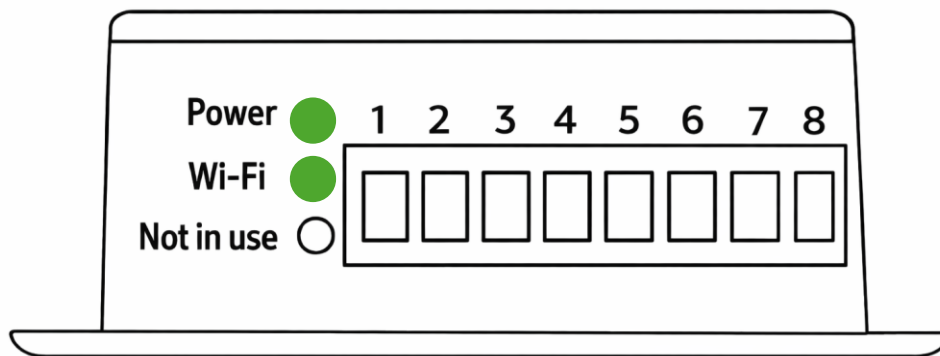

TESTING THE CONTROLLER



Local Unlock Verification

1. Open the app and navigate to the Unlock tab.
2. Confirm the Controller appears under the Nearby section.
3. Tap the Controller and wait for the unlock confirmation checkmark.
4. Verify the door physically unlocks.
5. Open and close the door, then confirm it relocks properly.
6. Adjust the relock time if necessary.

Remote Unlock Verification (Wi-Fi Required)

1. Open the app and navigate to the Unlock tab.
2. Confirm the Controller appears under the Remote section and displays Online.
3. Tap the Controller and wait for the unlock confirmation checkmark.
4. Verify the door unlocks.
5. Open and close the door, then confirm it relocks properly.
6. Adjust the relock time if necessary.

WI-FI SIGNAL STRENGTH (RSSI) GUIDELINES



When testing controller connectivity, verify the RSSI (Received Signal Strength Indicator) value.

Recommended RSSI Range

- -30 dBm to -60 dBm → Excellent
- -60 dBm to -67 dBm → Good / Acceptable
- -67 dBm to -70 dBm → Marginal

Below -70 dBm → Poor (may result in unreliable operation)

For reliable performance, the controller should maintain:

- -67 dBm or stronger (closer to 0).

If Signal Strength Is Too Low

Router or Wi-Fi access point should be within 30 feet of the Controller with minimal obstructions.

Do not relocate the controller to improve signal.

If RSSI is weaker than -67 dBm, improve Wi-Fi coverage by:

- Moving the wireless access point closer to the door
- Adding a Wi-Fi access point near the installation location
- Installing a Wi-Fi extender or mesh node
- Removing the router from metal enclosures
- Reducing interference from nearby equipment

CONTROLLER SETTINGS 1/2



This section will provide an overview of the Controller's settings. For a full guide visit <https://www.nexkey.com/guides>

Name the Controller

Assign a clear, descriptive name to the Controller to easily identify the door it controls. Optionally you can add a nickname.

Business Hours

Configure Business Hours to define when a door should remain unlocked.

- The Controller will automatically unlock the door at the start of the schedule.
- The Controller will automatically relock the door when the schedule ends.

Blackout

Configure Blackout Days to specify calendar dates when user access is denied.

- During a blackout:
 - The door will not automatically unlock for Business Hours.
 - Users with time-restricted keys (one-time keys, scheduled keys) and Text Keys will be denied access.
- Admins are not affected by blackout days and will retain access.

Wi-Fi Configuration

Configure Wi-Fi settings to enable remote unlocking, Text Keys, and Business Hours functionality.



Firmware Update

Update the Controller firmware to ensure the latest features, performance improvements, and security updates are applied.

Time Zone

Set the Controller time zone to match the installation location.

- The default time zone is Pacific Standard Time (PST).
- Correct time zone configuration is required for accurate schedules and activity logs.

Relock Time

Adjust the relock time to control how long the locking hardware remains unlocked after an unlock event. By default, the relock time is set to 6 seconds.

SUPPORT



Thank you for choosing Nexkey.
If you need assistance or encounter any issues during installation, please contact us right away.

<https://www.nexkey.com/support>
(888) 413-7093
support@nexkey.com

Visit our YouTube page that has helpful tutorials on how to operate and manage Nexkey devices.
<https://www.youtube.com/@Nexkey>

Sincerely,
The Nexkey Team

Revisions

Version	Date	Content
1.0	2/2025	webpage instructions
2.0	1/2026	Updated downloadable document
2.1	3/2026	Updated commissioning link, wiring graphics and Wi-Fi guidelines
2.1.1	5/2026	Updated compatible locking hardware